

GENERAL NOTES:

1. MODEL NUMBER: IH-X-2-H-G-D-N-3-2-N-N-1A
2. FRAME HARDWARE: NONE
3. FACEGUARD MATERIAL: NONE
4. EXTRACTION CLIPS: N/A
5. CHALLENGE AEROSOL: PAO
6. FRAME STYLE: DOUBLE TURN FLANGE

MATERIAL NOTES:

1. FILTER MEDIA: 99.9995% @ 0.1-0.2 MICRONS
2. SEPARATOR MATERIAL: CORRUGATED, 0.0015" THICK, 1145 ALUMINUM
3. FRAME MATERIAL: 16 GA. GALVANIZED
4. SEALANT MATERIAL: 2 PART POLYURETHANE
5. SEAL TYPE: NEOPRENE GASKET, DOWNSTREAM
6. PACK STYLE: HIGH CAPACITY

FILTER SPECIFICATIONS:

1. PLEAT DEPTH: 4-7/8"
2. EFFICIENCY: 99.9995% @ 0.1-0.2 MICRONS
3. FILTER SIZE (ACTUAL): 12 x 12 x 5-7/8"
4. TEST FLOW: 100 CFM

FRAME TOLERANCES:

1. LENGTHS: +0 / -1/8"
2. DIAGONALS: WITHIN 1/8" TOTAL ALLOWANCE FOR DIAGONALS <30"
WITHIN 1/4" TOTAL ALLOWANCE FOR DIAGONALS >30"

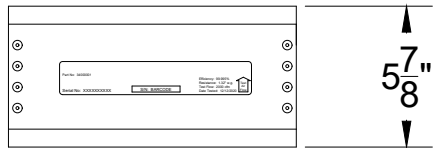
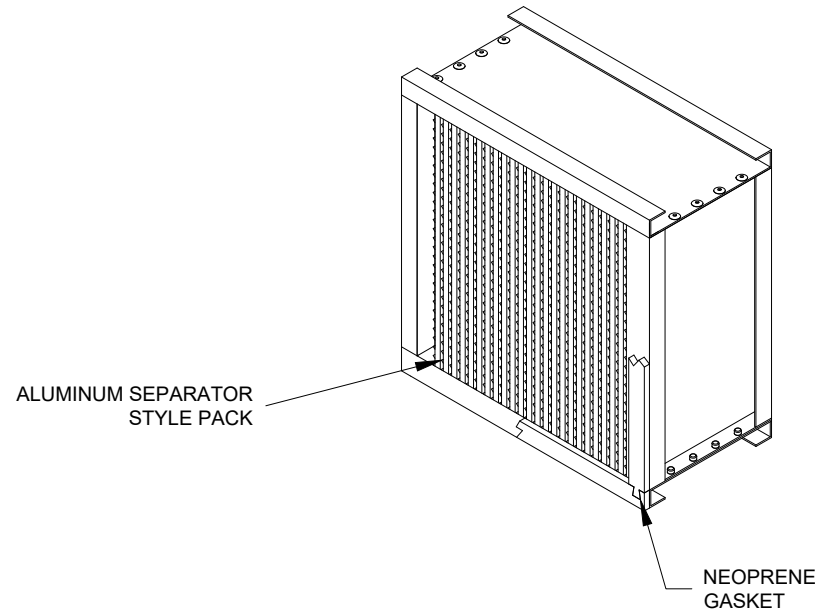

TOP VIEW

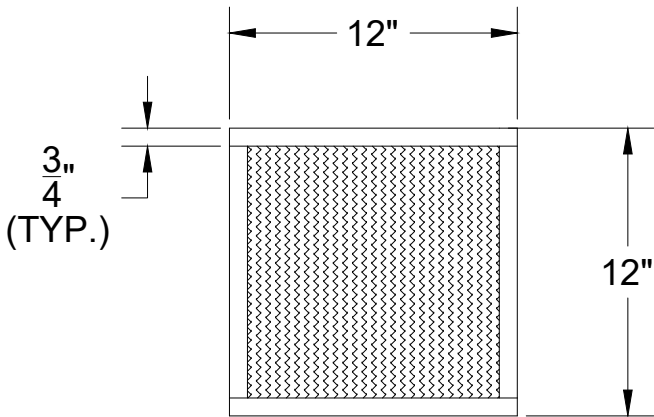

FRONT VIEW

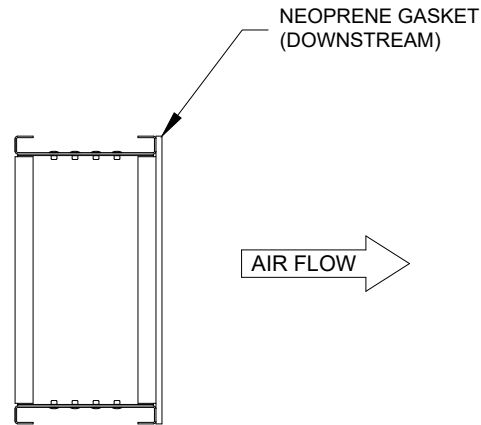

SIDE VIEW

EXTRACT-ALL

Air Impurities Removal Systems, Inc.
166 North 121st Street
Wauwatosa, WI 53226
Toll Free: #800-236-1889

DESCRIPTION:
EXTRACT-ALL SERIES ULPA
99.9995% ULPA, 16 GA. GLV, HIGH CAPACITY, GASKET SEAL
MODEL NUMBER: RF-987-ULPA

REV	DRAWN BY DATE	DESCRIPTION:	APPR. BY DATE	DRAWN BY: NPR	DATE:	DRAWING NUMBER	SHEET	OF	REV
		INFORMATION CONTAINED ON THIS DOCUMENT IS PROPRIETARY TO PAMLIKO AIR AND MAY NOT BE REPRODUCED OR TRANSMITTED TO OTHER PARTIES WITHOUT THE WRITTEN CONSENT OF PAMLIKO AIR		CHECK BY: CFK	DATE:	PB21-0016	1	1	0
DIMS SCALE = 0.0000 FILENAME: PB21-0016.dwg									